

* * NOTES * *

1. MATERIAL CAST STEEL PER AISI 1045
2. MATERIAL STEEL PER ASTM A36
3. CASTINGS HAVE (3) GROUT HOLES

SHIM

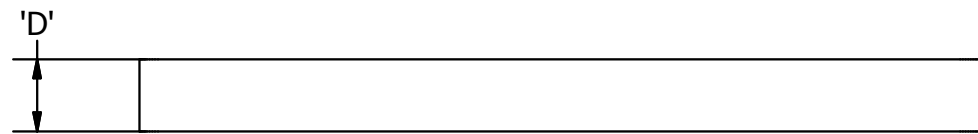
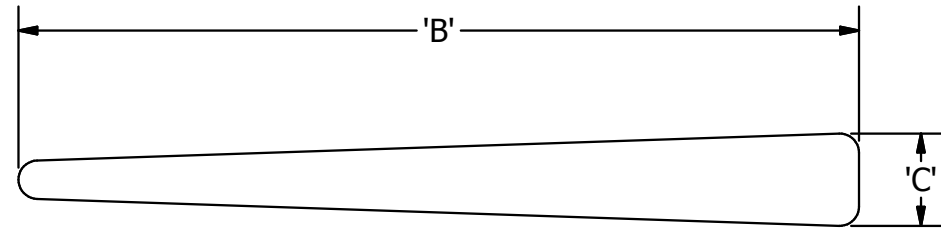
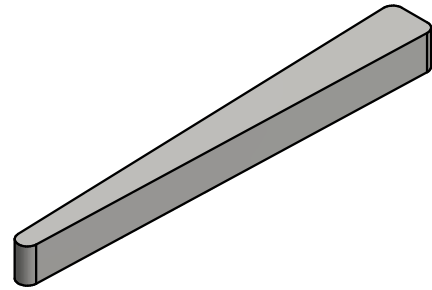

EXTENSION DISPLACEMENT PLATE

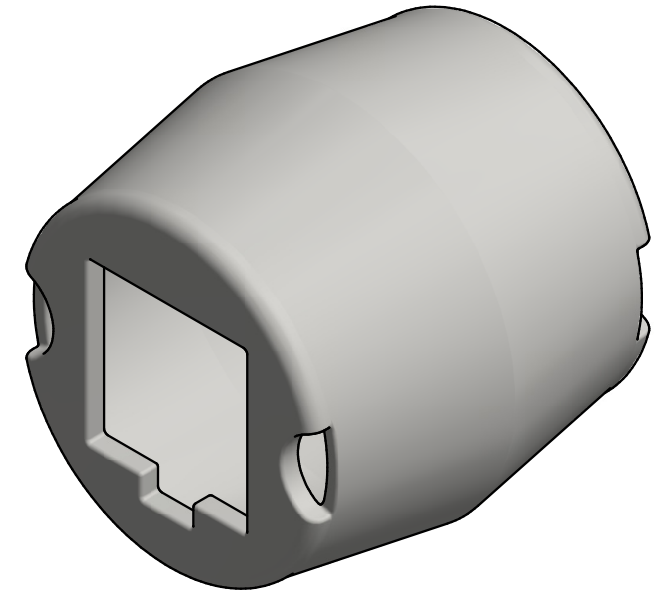
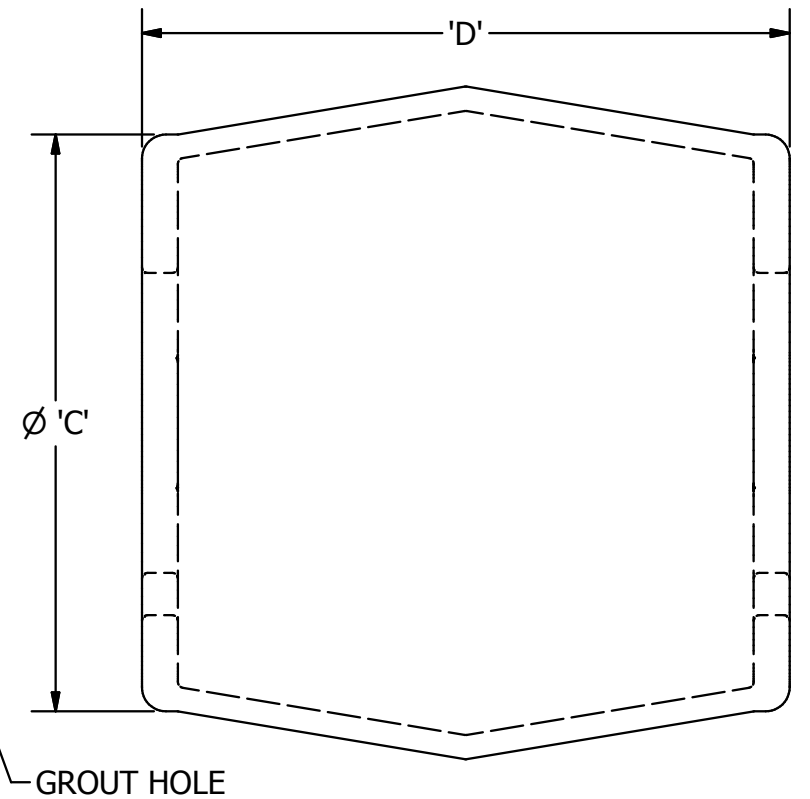
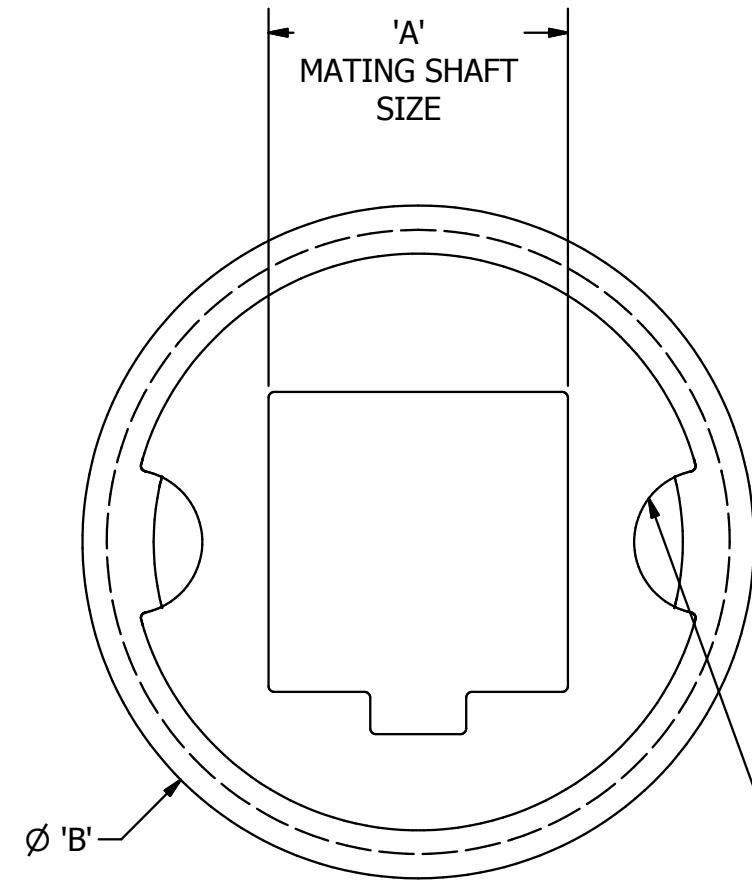

| PART NUM | DESCRIPTION | NOTES | 'A' | 'B' | 'C' | 'D' |
|----------|-------------------------------|-------|-----------|-----|-----|------|
| C1501065 | HPM EDP, SS175, 3.85 INCH DIA | 1 | SS175 | 4.6 | 3.6 | 3.38 |
| C1501064 | HPM EDP, SS150, 3.25 INCH DIA | 1 | SS5/SS150 | 3.5 | 3.0 | 3.38 |
| C1501362 | HPM EDP, SS200, 5.50 INCH DIA | 1, 3 | SS200 | 5.5 | 4.5 | 4.00 |
| C1501391 | SHIM, HPM | 2 | N/A | 4.4 | 0.5 | 0.38 |

CHANCE®

CONFIDENTIAL: THIS DRAWING AND ITS CONTENTS ARE CONFIDENTIAL AND THE EXCLUSIVE PROPERTY OF HUBBELL POWER SYSTEMS. NO PUBLICATION, DISTRIBUTION OR COPIES MAY BE MADE WITHOUT THE WRITTEN CONSENT OF HUBBELL POWER SYSTEMS. HUBBELL POWER SYSTEMS UNPUBLISHED ALL RIGHTS RESERVED UNDER THE COPYRIGHT LAWS.



HUBBELL POWER SYSTEMS, Inc.

TITLE
HELICAL PULLDOWN MICROPILE CONICAL DISPLACEMENT PLATES

| | | | |
|---------------------------|---|-----------------------------|-----------------|
| SIZE SB | CAT / PART / ASSY NO. SEE CHART | DWG NO. SA1501064 | REV E |
| DO NOT SCALE THIS DRAWING | DRN BY TMK | DATE 12/11/13 | SHEET 1 - 2 |

* * NOTES * *

1. MATERIAL CAST STEEL PER AISI 1045

STYLE 1

STYLE 2

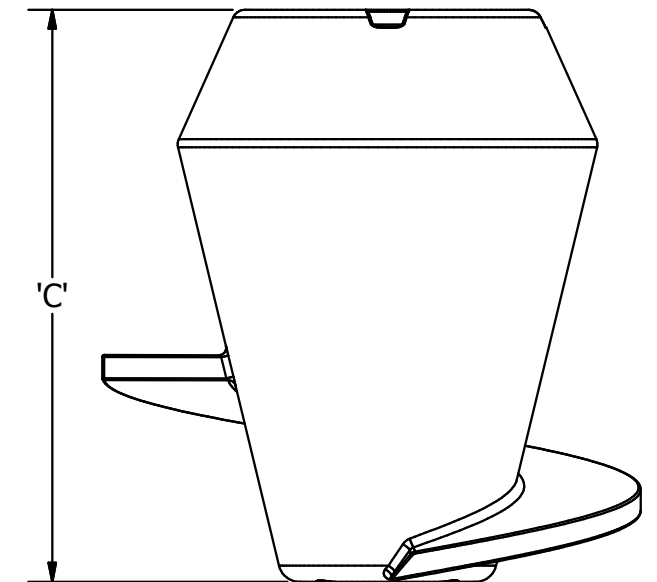
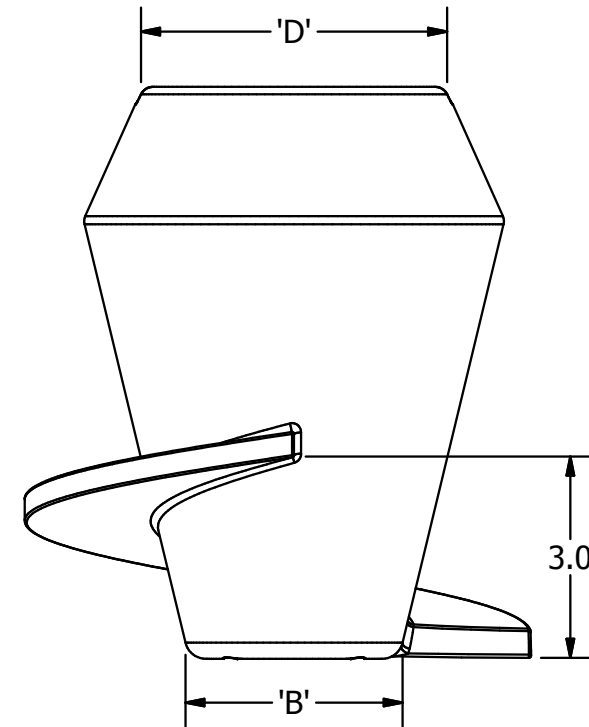
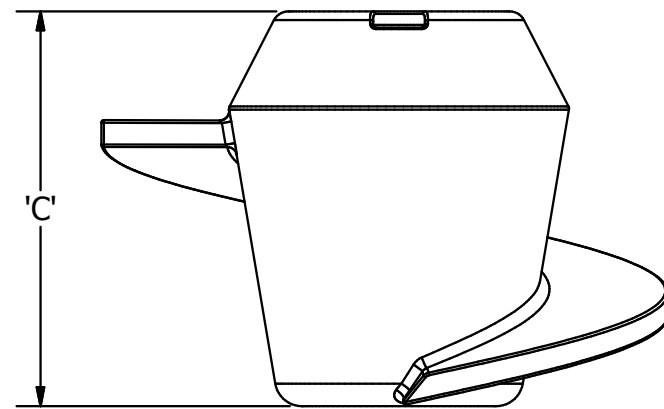
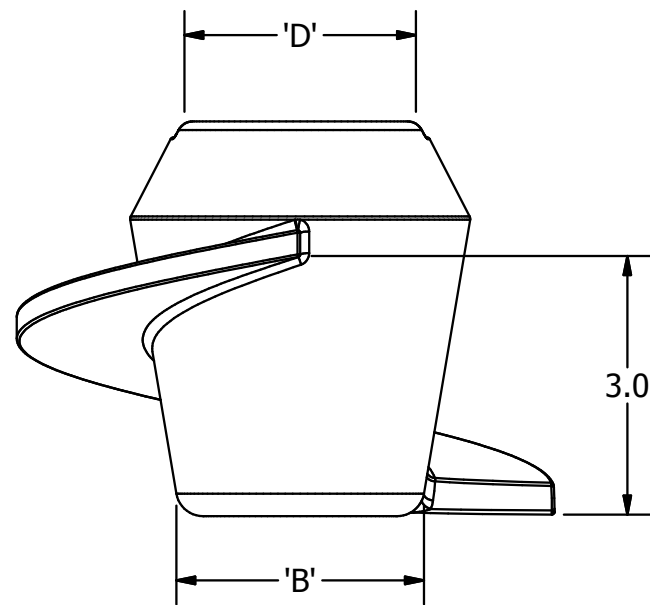
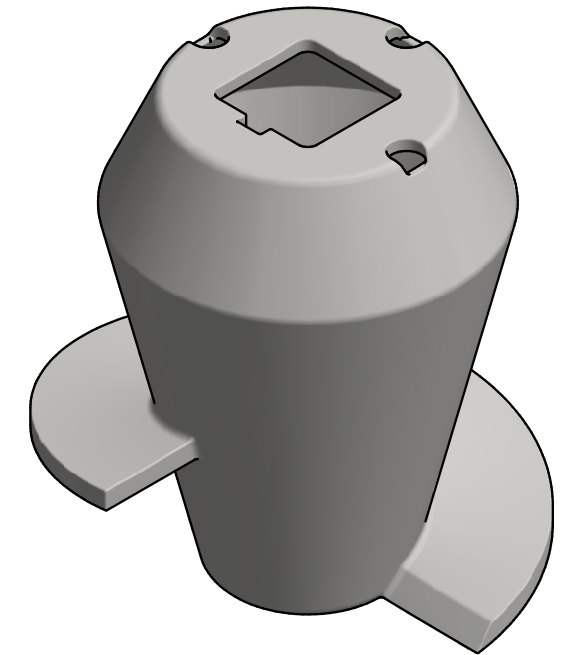
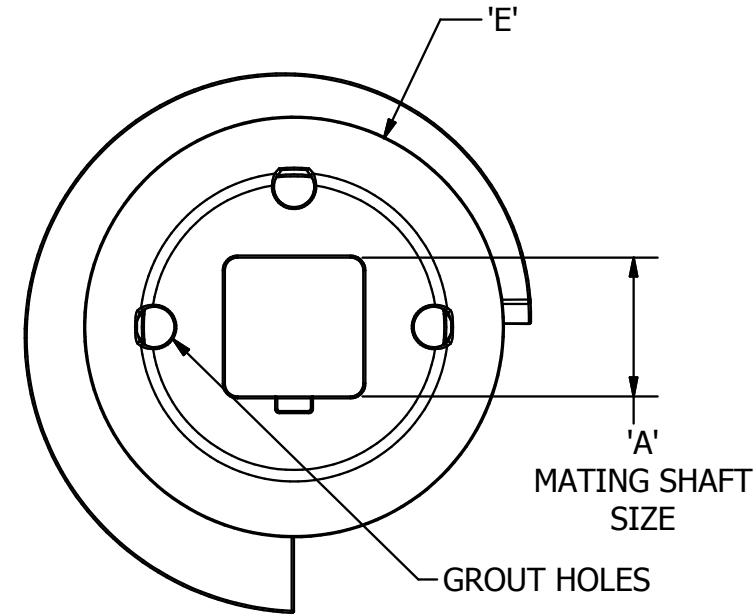
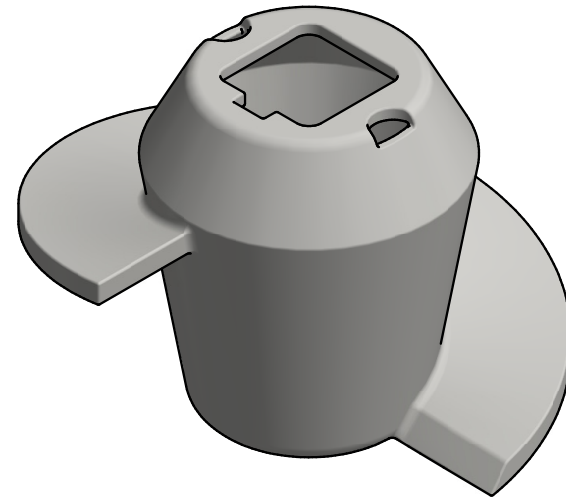
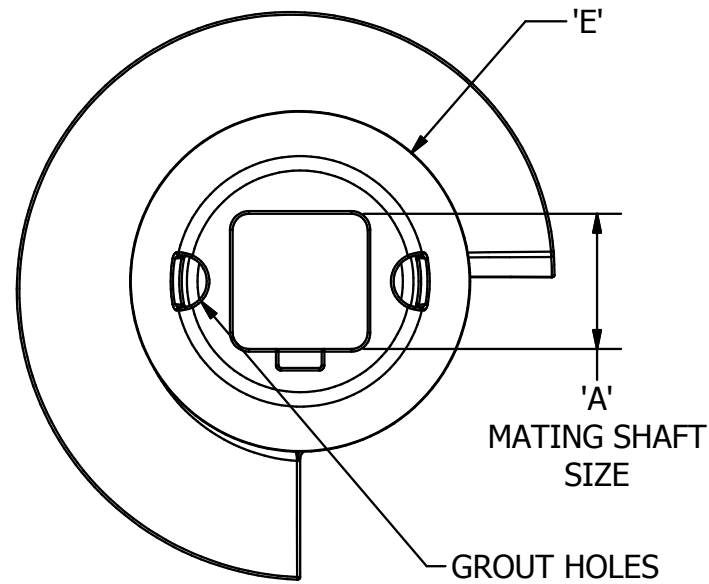

| PART NUM | DESCRIPTION | 'A' | 'B' | 'C' | 'D' | 'E' | STYLE |
|----------|-------------------------|-------|------|------|------|------|-------|
| C1501352 | HPM LDP, SS150, 3.25 IN | SS150 | 2.90 | 4.56 | 2.90 | 3.94 | 1 |
| C1501353 | HPM LDP, SS175, 4.00 IN | SS175 | 3.40 | 5.25 | 3.60 | 4.87 | 1 |
| C1501360 | HPM LDP, SS200, 5.50 IN | SS200 | 3.25 | 8.50 | 4.59 | 6.25 | 2 |

CHANCE®

CONFIDENTIAL: THIS DRAWING AND ITS CONTENTS ARE CONFIDENTIAL AND THE EXCLUSIVE PROPERTY OF HUBBELL POWER SYSTEMS. NO PUBLICATION, DISTRIBUTION OR COPIES MAY BE MADE WITHOUT THE WRITTEN CONSENT OF HUBBELL POWER SYSTEMS. HUBBELL POWER SYSTEMS UNPUBLISHED ALL RIGHTS RESERVED UNDER THE COPYRIGHT LAWS.



HUBBELL POWER SYSTEMS, Inc.

TITLE
HELICAL PULLDOWN MICROPILE CONICAL DISPLACEMENT PLATES

| | | | |
|---------------------------|---|-----------------------------|-----------------|
| SIZE SB | CAT / PART / ASSY NO. SEE CHART | DWG NO. SA1501064 | REV E |
| DO NOT SCALE THIS DRAWING | DRN BY TMK | DATE 12/11/13 | SHEET 2 - 2 |