

# COMPRESSION/TENSION NEW CONSTRUCTION PILE CAPS

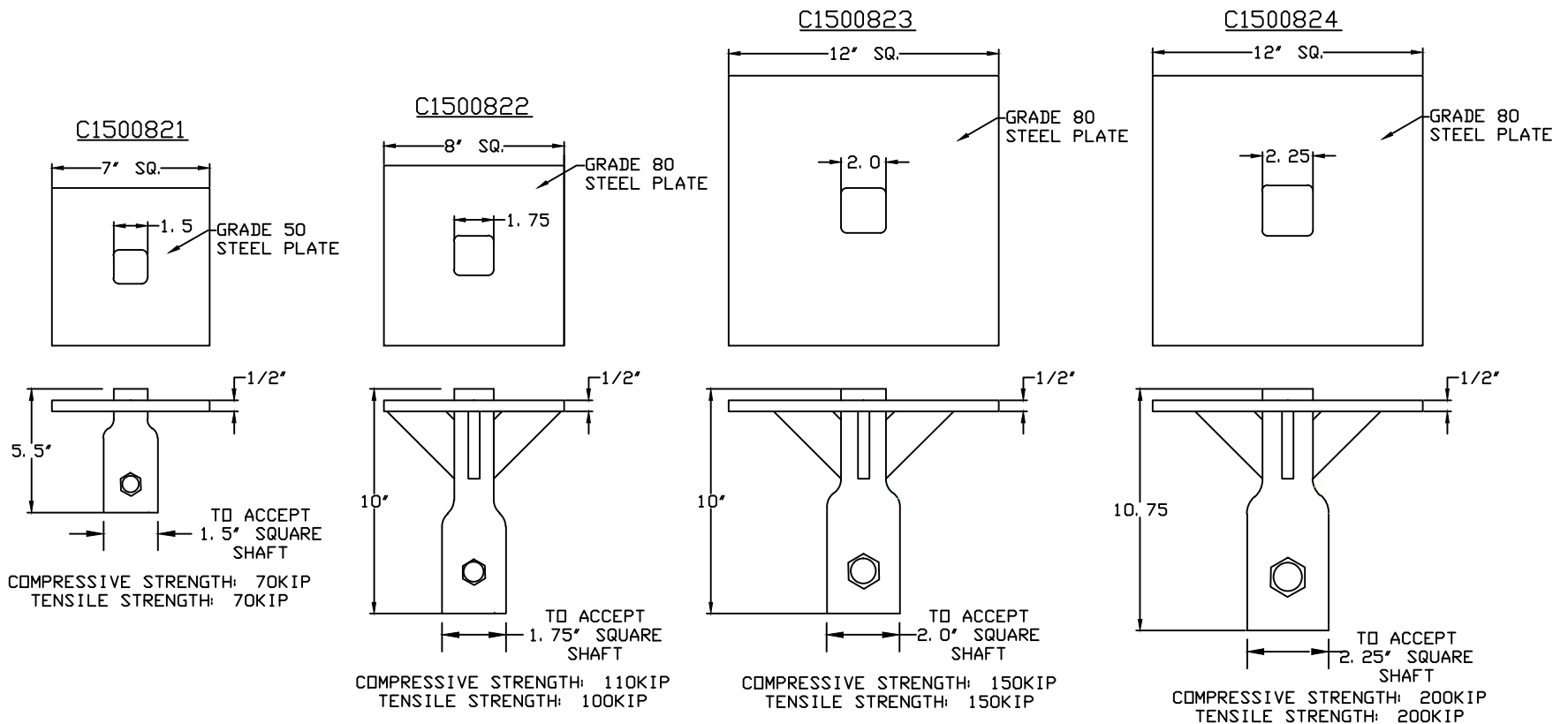

## =NOTES=

1. FINISH: STANDARD CATALOG NUMBER IS MILL FINISH STEEL.  
 TO ORDER GALVANIZED FINISH ADD "G" TO STANDARD CATALOG NUMBER.
2. MATERIAL SPECIFICATIONS:  
 PLATE: HOT ROLLED STEEL PLATE PER ASTM A572 GRD. 50.  
 OR HOT ROLLED STEEL PLATE PER ASTM A656 GRD. 80.  
 SOCKET: ROUND CORNER SQUARE STEEL BAR PER TT-76  
 BOLT: 3/4" HEX HEAD BOLTS PER ASTM A325 TYPE 1.  
 7/8", 1-1/8", AND 1-1/4" HEX HEAD BOLTS PER ASTM A193.

<b>CHANCE</b> TOLERANCE CHART	<b>HUBBELL POWER SYSTEMS</b>
TITLE <b>COMPRESSION/TENSION                  NEW CONSTRUCTION PILE CAP</b>	
CONFIDENTIAL: THIS DRAWING AND ITS CONTENTS ARE CONFIDENTIAL AND THE EXCLUSIVE PROPERTY OF HUBBELL POWER SYSTEMS. NO PUBLICATION, DISTRIBUTION OR COPIES MAY BE MADE WITHOUT THE WRITTEN CONSENT OF HUBBELL POWER SYSTEMS. HUBBELL POWER SYSTEMS UNPUBLISHED. ALL RIGHTS RESERVED UNDER THE COPYRIGHT LAWS.	SIZE DWG NO. CAT / PART / ASSY NO. REV SB SA1500821 SEE DRAWING C
DO NOT SCALE THIS DRAWING	DRN BY TLW DATE 8/12/11 SHEET 1 OF 1