

# COMPRESSION ONLY NEW CONSTRUCTION REBAR PILE CAPS

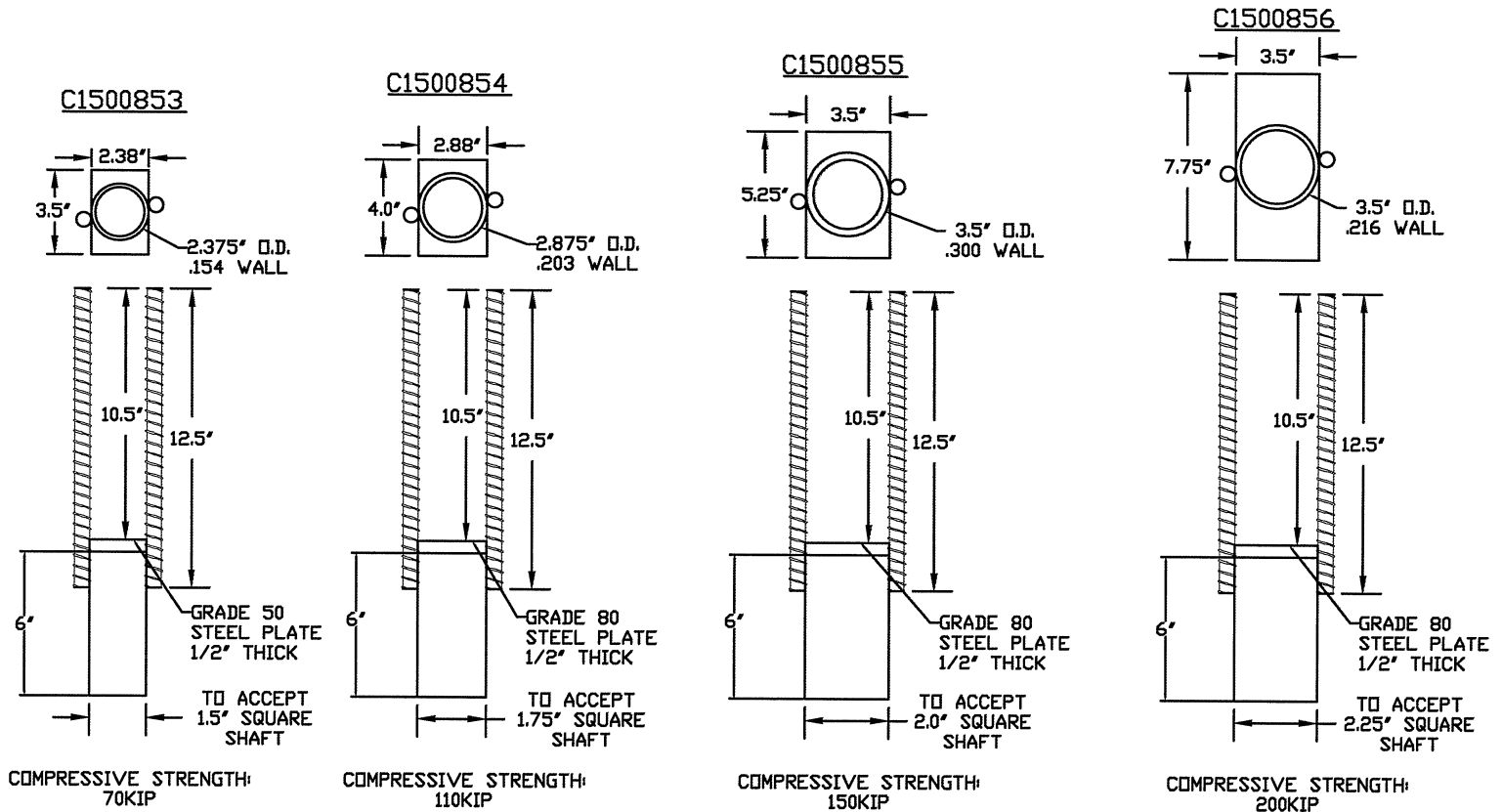

## =NOTES=

1. FINISH: STANDARD CATALOG NUMBER IS MILL FINISH STEEL. TO ORDER GALVANIZED FINISH ADD 'G' TO STANDARD CATALOG NUMBER.
2. MATERIAL SPECIFICATIONS:  
 PLATE: HOT ROLLED STEEL PLATE PER ASTM A572 GRD. 50.  
 OR HOT ROLLED STEEL PLATE PER ASTM A656 GRD. 80.  
 PIPE: ERW PIPE PER ASTM A53 GRADE B OR PER ASTM A500 GRADE 50.

CHANCE TOLERANCE CHART	<b>HUBBELL POWER SYSTEMS</b> <small>POWER SYSTEMS, INC.</small>
TITLE <b>COMPRESSION ONLY</b>	
<b>NEW CONSTRUCTION REBAR PILE CAPS</b>	
CONFIDENTIAL: THIS DRAWING AND ITS CONTENTS ARE CONFIDENTIAL AND THE EXCLUSIVE PROPERTY OF HUBBELL POWER SYSTEMS. NO PUBLICATION, DISTRIBUTION OR COPIES MAY BE MADE WITHOUT THE WRITTEN CONSENT OF HUBBELL POWER SYSTEMS. HUBBELL POWER SYSTEMS UNPUBLISHED ALL RIGHTS RESERVED UNDER THE COPYRIGHT LAWS.	SIZE DWG NO. CAT / PART / ASSY NO. REV SB SA150-0853 SEE DRAWING B
DO NOT SCALE THIS DRAWING	DRN BY TLW DATE 8/12/11 SHEET 1 OF 1