

SS5 HELICAL PIERS AND ANCHORS GRADE 80 HELIX

TORQUE STRENGTH RATING-5,500 FT-LB
 ULTIMATE CAPACITY*(TENSION/COMPRESSION)-55 KIP
 * BASED ON A TORQUE FACTOR (Kt)=10
 SINGLE HELIX ULTIMATE STRENGTH-40 KIP 3/8", 50 KIP 1/2"
 ULTIMATE TENSION STRENGTH (COUPLING BOLT)-70 KIP

CAT. NO.	A	B	C	F	G	T
T150-0269	82'	8'	--	79'	3'	3/8"
T150-0268	59'	8'	--	56'	3'	3/8"
T150-0267	59'	10'	--	56'	3'	3/8"
T150-0266	82'	12'	--	79'	3'	3/8"
T150-0265	82'	8'	10'	55'	3'	3/8"
T150-0326	82'	10'	--	79'	3'	3/8"
T150-0442	59'	10'	12'	23'	6'	3/8"
T150-0443	59'	8'	10'	29'	6'	3/8"
T150-0469	42'	8'	--	39'	3'	3/8"
T150-0304	82'	8'	--	79'	3'	1/2"
T150-0305	59'	8'	--	56'	3'	1/2"
T150-0444	59'	8'	10'	17'	6'	1/2"
T1500495	59'	6'	--	56'	3'	1/2"
T1500497	59'	6'	--	56'	3'	3/8"

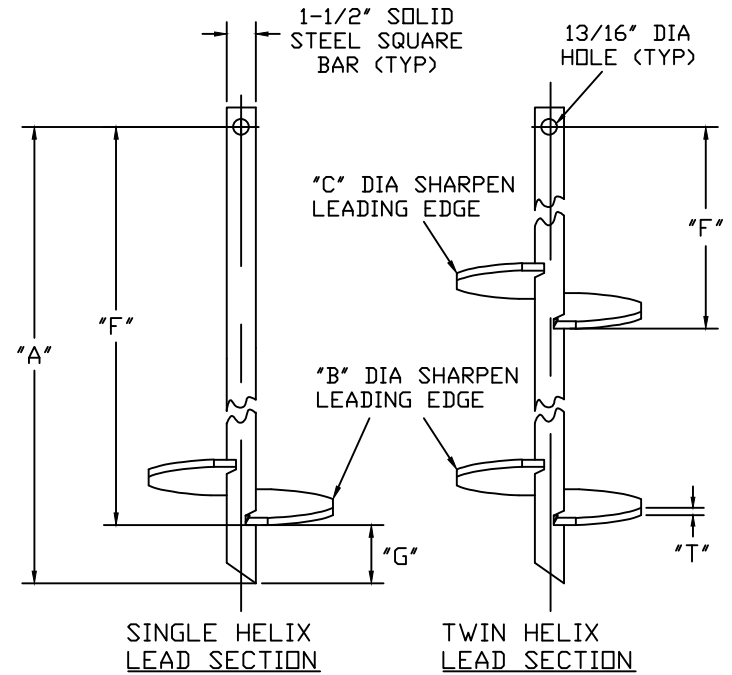

-NOTES-

- HOT DIP GALVANIZED PER ASTM A153-(LATEST REV.)
- LEAD AND EXTENSION SECTION AND PILOT POINT LENGTHS ARE NOMINAL.
- SHAFT MATERIAL-HOT ROLLED ROUND-CORNERED SQUARE (RCS) SOLID STEEL BARS PER ASTM A29; MINIMUM YIELD STRENGTH=70 KSI.
- HELIX MATERIAL-HOT ROLLED LOW CARBON STEEL SHEET, STRIP, OR PLATE PER ASTM A656, OR A1018 GRADE 80; MINIMUM YIELD STRENGTH=80 KSI.
- COUPLING BOLTS: 3/4" DIAMETER X 3" LONG HEX HEAD PER ASTM A325 TYPE 1,
- NOMINAL SPACING BETWEEN HELICAL PLATES IS THREE TIMES THE DIAMETER OF THE LOWER HELIX.
- MANUFACTURER TO HAVE IN EFFECT INDUSTRY RECOGNIZED WRITTEN QUALITY CONTROL FOR ALL MATERIALS AND MANUFACTURING PROCESSES.
- ALL WELDING TO BE DONE BY WELDERS CERTIFIED UNDER SECTION 5 OF THE AWS CODE D1. 1.
- REFER TO DRAWING SA150-0047 FOR PLAIN EXTENSIONS AND TERMINATIONS.

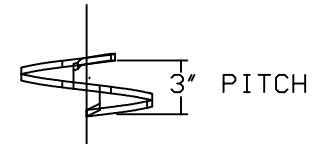

HELIX MUST BE FORMED BY MATCHING METAL DIE
(SIDE VIEW OF TRUE HELICAL FORM)

CHANCE	HUBBELL POWER SYSTEMS		
CONFIDENTIAL: THIS DRAWING AND ITS CONTENTS ARE CONFIDENTIAL AND THE EXCLUSIVE PROPERTY OF HUBBELL POWER SYSTEMS. NO PUBLICATION, DISTRIBUTION OR COPIES MAY BE MADE WITHOUT THE WRITTEN CONSENT OF HUBBELL POWER SYSTEMS. ALL RIGHTS RESERVED UNDER THE COPYRIGHT LAWS.		TITLE LEAD, SECTION SLG80 - SS5	
SIZE DWG NO. SC SA150-0269	CAT / PART / ASSY NO. SEE CHART	REV B	
DO NOT SCALE THIS DRAWING	DRN BY KSH	DATE 4/25/05	SHEET 1