

AP-2-UFB-3500-4000 UNDER FOOTING BRACKET
 CATALOG NO: PSA1001N [P] OR PSA1052N [G]

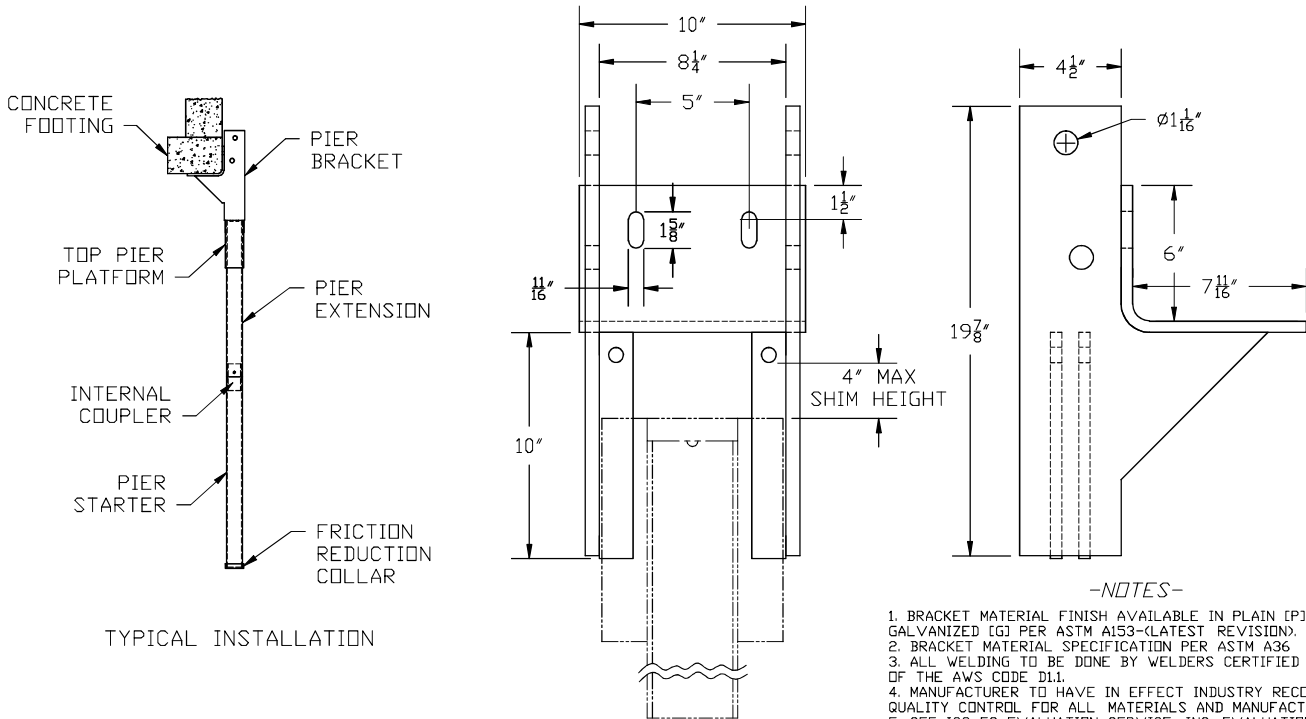

-NOTES-

1. BRACKET MATERIAL FINISH AVAILABLE IN PLAIN [P] OR HOT DIP GALVANIZED [G] PER ASTM A153-(LATEST REVISION).
2. BRACKET MATERIAL SPECIFICATION PER ASTM A36
3. ALL WELDING TO BE DONE BY WELDERS CERTIFIED UNDER SECTION 5 OF THE AWS CODE D1.1.
4. MANUFACTURER TO HAVE IN EFFECT INDUSTRY RECOGNIZED WRITTEN QUALITY CONTROL FOR ALL MATERIALS AND MANUFACTURING PROCESSES.
5. SEE ICC-ES EVALUATION SERVICE, INC. EVALUATION REPORT NO. NER-579 FOR THE AP-2-UFB-3500 AND 3500M SYSTEMS.
6. TWO 5/8 DIA PIER PINS (PART# PSA1030) CONFORMING TO ASTM A29 GRADE 10B21 ARE REQUIRED FOR EACH PIER.
7. LIFT SHIMS (PART# PSA1031 OR PSA1032) SHALL BE USED AS REQUIRED UP TO A MAXIMUM HEIGHT OF 4 INCHES.
8. REFER TO DRAWING SA1002N FOR TOP PIER PLATFORMS.
9. REFER TO DRAWING SA1003 FOR PIER SECTIONS.

AP-2-UF-3500/4000 SYSTEM COMPONENTS

Catalog No.	Pier System	Bracket (Qty)	Top Pier Platform (Qty)	Pier Section (Qty)	Starter Section (Qty)	Plain Pier Sleeve (Qty)	Modified Pier Sleeve (Qty)	Working Capacity (kips)	Ultimate Capacity (kips)
PSA1000N	AP-2-UF-3500.165 [PA] [14'-0"]	1	1	3	1	NA	NA	42.5	85
PSA1051N	AP-2-UF-3500.165 [GA] [14'-0"]	1	1	3	1	NA	NA	42.5	85
PSA1094N	AP-2-UF-3500.165M [PA] [14'-0"]	1	1	3	1	0 ²	1	45.5	91
PSA1104N	AP-2-UF-3500.165M [GA] [14'-0"]	1	1	3	1	0 ²	1	45.5	91
PSA1213N	AP-2-UF-4000.219 [P] [14'-0"]	1	1	3	1	NA	NA	49	98
PSA2977N	AP-2-UF-4000.219 [G] [14'-0"]	1	1	3	1	NA	NA	49	98

Notes:
 1 P = Plain Steel, A = Flow Coat Corrosion Protection, G = Hot Dipped Galvanized, M = Modified Pier
 2 Plain Pier Sleeves are not included in Item Nos: PSA1094N and PSA1104N and are only used if soil conditions warrant

ATLAS [®]		HUBBELL [®] POWER SYSTEMS	
AP-2-UFB-3500-4000[*] BRACKET			
TITLE		CAT / PART / ASSY. NO.	
SIZE	DWG NO.	SEE DWG	
A	SA1001N		
DO NOT SCALE THIS DRAWING		DRN BY SMS	DATE 6/27/07
		SHEET 1 OF 1	

CONFIDENTIAL: THIS DRAWING AND ITS CONTENTS ARE CONFIDENTIAL AND THE EXCLUSIVE PROPERTY OF HUBBELL POWER SYSTEMS, INC. NO PUBLICATION, DISTRIBUTION OR COPIES MAY BE MADE WITHOUT THE PRIOR WRITTEN CONSENT OF HUBBELL POWER SYSTEMS, INC. HUBBELL POWER SYSTEMS UNPUBLISHED. ALL RIGHTS RESERVED UNDER THE COPYRIGHT LAWS.