

AP-2-UFB-2875 UNDER FOOTING BRACKET
 CATALOG NO: PSA1034 [P] OR PSA1055 [G]

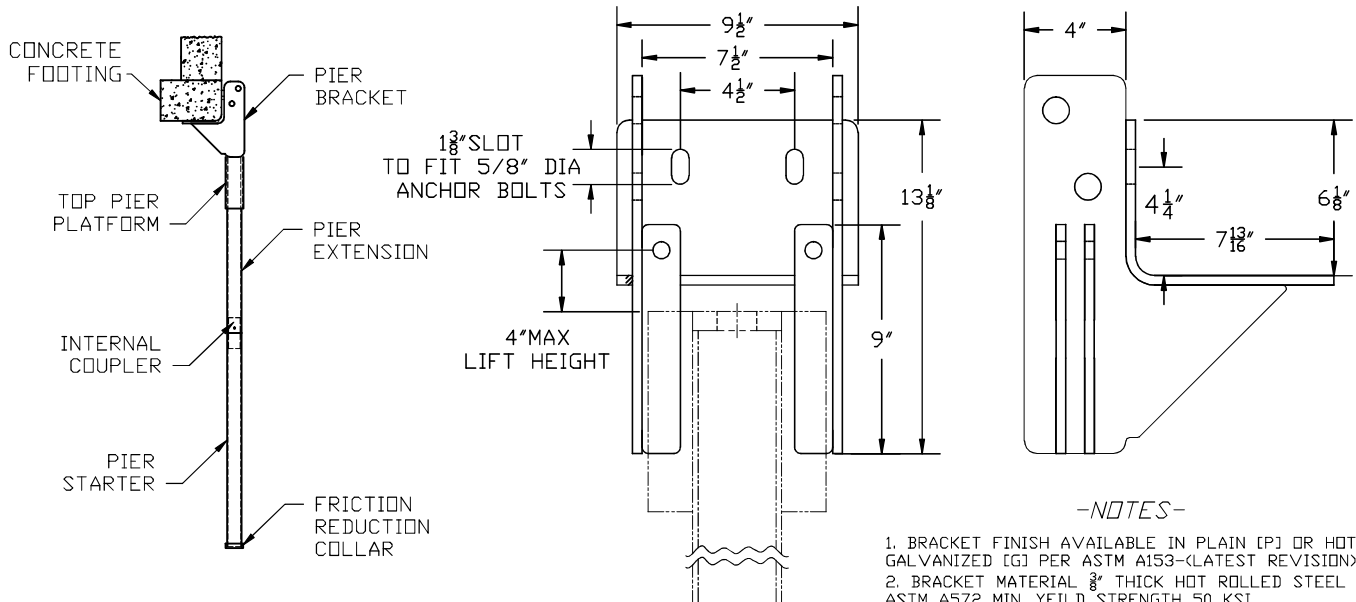

TYPICAL INSTALLATION

-NOTES-

1. BRACKET FINISH AVAILABLE IN PLAIN [P] OR HOT DIP GALVANIZED [G] PER ASTM A153-(LATEST REVISION).
2. BRACKET MATERIAL $\frac{3}{8}$ " THICK HOT ROLLED STEEL PER ASTM A572 MIN. YIELD STRENGTH 50 KSI.
3. ALL WELDING TO BE DONE BY WELDERS CERTIFIED UNDER SECTION 5 OF THE AWS CODE D1.1.
4. MANUFACTURER TO HAVE IN EFFECT INDUSTRY RECOGNIZED WRITTEN QUALITY CONTROL FOR ALL MATERIALS AND MANUFACTURING PROCESSES.
5. TWO 5/8 DIA PIER PINS (PART# PSA1030) CONFORMING TO ASTM A29 GRADE 10B21 ARE REQUIRED FOR EACH PIER.
6. LIFT SHIMS (PART# PSA1031 OR PSA1032) SHALL BE USED AS REQUIRED UP TO A MAXIMUM HEIGHT OF 4 INCHES.
7. REFER TO DRAWING SA1002 FOR TOP PIER PLATFORMS.
8. REFER TO DRAWING SA1003 FOR PIER SECTIONS.

AP-2-UFB-2875 SYSTEM COMPONENTS

Catalog No.	Pier System	Bracket (Qty)	Top Pier Platform (Qty)	Pier Section (Qty)	Starter Section (Qty)	Plain Pier Sleeve (Qty)	Modified Pier Sleeve (Qty)	Working Capacity (kips)	Ultimate Capacity (kips)
PSA1033	AP-2-UFB-2875.165 [P] [14'-0"]	1	1	3	1	NA	NA	30	60
PSA1847	AP-2-UFB-2875.165 [PA] [14'-0"]	1	1	3	1	NA	NA	30	60
PSA3936	AP-2-UFB-2875.165 [GA] [14'-0"]	1	1	3	1	NA	NA	30	60
PSA1054	AP-2-UFB-2875.165 [G] [14'-0"]	1	1	3	1	NA	NA	30	60
PSA4797	AP-2-UFB-2875.165M [P] [14'-0"]	1	1	3	1	0 ²	1	35	70
PSA4798	AP-2-UFB-2875.165M [PA] [14'-0"]	1	1	3	1	0 ²	1	35	70
PSA4799	AP-2-UFB-2875.165M [GA] [14'-0"]	1	1	3	1	0 ²	1	35	70
PSA4800	AP-2-UFB-2875.165M [G] [14'-0"]	1	1	3	1	0 ²	1	35	70

Notes:
 * P = Plain Steel, A = Flow Coat Corrosion Protection, G = Hot Dipped Galvanized, M = Modified Pier
 † Plain Pier Sleeves are not included in item Nos: PSA4797, PSA4798, PSA4799 and PSA4800 and are only used if soil conditions warrant

ATLAS [®]		HUBBELL [®] POWER SYSTEMS	
AP-2-UFB-2875[*] BRACKET			
CONFIDENTIAL: THIS DRAWING AND ITS CONTENTS ARE CONFIDENTIAL AND THE EXCLUSIVE PROPERTY OF HUBBELL POWER SYSTEMS, INC. NO PUBLICATION, DISTRIBUTION OR COPIES MAY BE MADE WITHOUT THE PRIOR WRITTEN CONSENT OF HUBBELL POWER SYSTEMS, INC. HUBBELL POWER SYSTEMS UNPUBLISHED. ALL RIGHTS RESERVED UNDER THE COPYRIGHT LAWS.			
TITLE	SIZE	CAT / PART / ASSY NO.	REV
A	SA1034	SEE DWG	C
DO NOT SCALE THIS DRAWING	DRN BY SMS	DATE 3/9/07	SHEET 1 OF 1